

SUGGESTED RETAIL PRICE \$4.20



FREE AT SELECT CANADIAN LOCATIONS



ISSUE 79

# HIGH! CANADA MAGAZINE

#79 FEBRUARY 2023

NOW IN OUR 9TH YEAR OF PUBLISHING  
CANADA'S FAVOURITE CANNABIS MAGAZINE



FIRA DE CORNELLÀ - BARCELONA - 10, 11 Y 12 DE MARZO 2023

# SPANNABIS

XIX FERIA DEL CÁÑAMO  
LA FERIA MÁS GRANDE DEL MUNDO



ORGANIZADORES



**Cannabis**  
Magazine

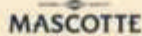
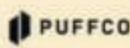

EXPOSICIONES | CONFERENCIAS | MÚSICA | DESCUENTOS Y REGALOS CON TU ENTRADA

ENTRADAS ANTICIPADAS: [WWW.SPANNABIS.ES](http://WWW.SPANNABIS.ES) | SÍGUENOS POR



MANTRA

CANNABIS

CREATING MOMENTS OF MAGIC



FROM THE ASHES,  
WE RISE.

WE ARE PROUD TO DONATE A  
PERCENTAGE OF OUR REVENUE TO

**YWCA** | EDMONTON

**YWCA** | EDMONTON



NOW  
*Available*

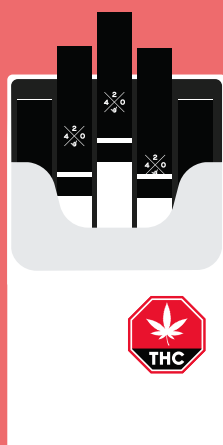

## Lip Service

420s - 10 x 0.42g Full Flower Slim Pre-Rolls  
[allgoodcollective.ca](http://allgoodcollective.ca)

*All  
Good*  
COLLECTIVE



# HIGH! CANADA MAGAZINE

I S S U E 7 9 - F E B R U A R Y 2 0 2 3

Driven by a balanced approach to ensuring responsible cannabis choices and creating positive cannabis experiences for Canadians, HCM strives to inform and educate our readers. HCM is not responsible for the actions, services or quality of the products and services represented within or reported on.

All material presented is intended for a mature 19+ audience and is intended for entertainment, educational and informational purposes only.

For more information on medicinal cannabis, please speak to your family Doctor.

HCM is distributed to age verified, legal Canadian cannabis shops and by mail out subscription.

All rights reserved, HCM is printed and produced proudly in Canada. For more information on HCM, please email us at [editor@highcanada.net](mailto:editor@highcanada.net) or visit us online at [www.highcanada.net](http://www.highcanada.net)

**Cy Williams**  
Publisher/Editor

**Tammi Stanhope**  
Ontario Editorial Team

**Dave Mac Adam**  
BC Editorial Team

**Xander Landry**  
BC Editorial Team

**Sara Jane Wilson**  
BC Editorial Team

**TF Pruden**  
Alberta Editorial Team

**Sabrina Mohamed**  
Ontario Editorial Team

**Harry White**  
Ontario Editorial Team

**Zara Boorder**  
Ontario Editorial Team

**Rainbow Smithe**  
BC Editorial Team

**Debi Facy**  
Ontario Editorial Team

**Lissa Skitolsky**  
Guest Contributor

**Harry Resin**  
BC Editorial Team

**CANADA'S LEGAL CANNABIS  
CULTURE MAGAZINE**

*[www.highcanada.net](http://www.highcanada.net)*

# HIGH! CANADA MAGAZINE

*At High Canada Magazine Publishing Group, we are committed to providing our readers with the most current, relevant, and reliable information available.*

*To help us maintain the editorial excellence and integrity of our publication, we have assembled a qualified Council of dedicated experts and innovators and natural health and cannabis to serve on HCM's Editorial Advisory Board:*

*With the help of these industry authorities, HCM offers fresh timely and accurate information about natural health and wellness as it applies to cannabis. The board members lend their expertise to our process of developing and commissioning or editorial lineup, and they're post-publication review of each issue is an invaluable in maintaining our more than six year reputation as Canada's most trusted cannabis health and wellness resource.*

*Every effort is made to ensure that the majority of advertised products will be available for sale in Canada.*

*The information provided in this magazine is for educational and informational purposes only. It should not be used as a substitute for the advice of qualified and licensed practitioner or healthcare provider.*

*The opinions expressed here are not necessarily those of High Canada Publishing Group, it's affiliates or parent company. Different views may appear in future articles or publications. Articles in HCM are copyrighted and must not be reprinted duplicated or transmitted without permission.*

## Editor's Notes by Cy Williams

**W**e are excited to be celebrating the second issue of our 9th year of publishing **High! Canada Magazine**.

On behalf of our entire High! Canada Magazine team - scattered across this amazing country of ours - we would like to welcome you back to another issue of information and education centered around cannabis in Canada. As you know, we focus on the people behind the plant and we have an exciting issue for you full of phenomenal people, inspirational stories and so much love and cannabis inspired love at that!

On behalf of our entire team, I would like to wish you a very celebratory **Black History Month** and remind you to support some of the amazing Black-owned cannabis-centric companies out there that are making a real difference in our space as true champions of the plant.

Amazing women like our **High! Canada Magazine** long-time contributor Sabrina Mohamed aka the very wonderful **TrimQueen** as well as the Jamaican-born cannabis activist - Vivianne Wilson, founder of **GreenPort**, and Ashley Athill, Co-founder of **HRVSTR** - both in Ontario.

There are also awesome men like Keenan Pascal, CEO of **Token Naturals** in Alberta as well as Josh Creighton, Tyler Creighton and Trano Creighton - the three brothers who are also the three co-owners of **Fumes Rolling Papers & Accessories** in Nova Scotia. This is to name just a few of the amazing people out there fighting for both the plant and inclusivity within our industry.



# A Terminator-Inspired Robot Uprising?

On the Canadian cannabis media side of things don't sleep on the on-point media created by Onell Crawford from the **Cannabis Related** podcast or own own High! Canada reporter, Debi Facey from the **Collective High** or Jimmi and Guz from the **Fried Chicken Podcast**. So many great people and if you are not supporting them in the space you should be.

This issue we also look at something a number of people are already discussing and with most discussions of this nature - there is much debate and almost every discussion of this nature ends circling around the singularity - what am I talking about?

## A Terminator-inspired robot uprising?

No... Well... sort of...

If you are a writer, artist, musician, designer, marketer or entrepreneur - you have to see that the writing is on the wall and that writing was put there by artificial intelligence or for short - A.I. as it has come to be commonly known by. Our time in the sun as we knew it is over. The world it is changing and sometimes it

seems to be changing faster and faster. All we can do is our best to keep up - know what I mean?

## Speaking of keeping up - why not consider getting ahead?



What do I mean?

Well... let me tell you.

I was recently invited to try out a new web browsing platform - it is kind of like... if Explorer or Chrome or Firefox fell in love with social media and they had a baby - this baby was brought up by creatives and taught to excel at creating content thru communication. This program is called **HVR** (think hover) and it is fricking amazing! If you are a member of the cannabis space in North America or anywhere around the world - you are likely aware of the difficulties involved in running a cannabis based social media account, let alone a website or a blog or tying these all together into a web of community. I have too many apps on my phone already and while my first



# No! It's a Cannabis Community Takeover of HVR!

reaction was “*Oh no! Not one more app!*” . How wrong I was because this was different.

I quickly changed my tune when I saw what **HVR** could do for me personally as a creator, what it could do for the magazine and for our entire community... I now had the opportunity to open one browser on my phone, use the web as I normally do, but I now had the ability to comment on any single page on the web and then have those comments and sites I had visited as easily accessible as my main **Instagram** feed.

My ability as a creator to drive traffic to our **Youtube** channel, to our website, to our content and to our media just got a level-up. I am not saying forget your current social media. If you love posting on **Social Club** in the morning, **Youtube** in the afternoon, **Facebook** in the evening and **Twitter** before bed - well keep doing that, but wouldn't it be cool to do all of that from one main site that is dedicated to your brand, your vision and your creative energy?

Ok, what's it going to cost you? The answer is nothing

- instead - it is going to put money in your pocket as the creative driving force behind your brand.

How can you get **HVR**? Well... a current **HVR** member has to invite you and lucky for you, my high Canada family. I am here to do just that...

Do you remember how the cannabis industry basically took over the job-hunting site **Linkedin** a few years ago? If you work in cannabis and have a **Linkedin** account then you know exactly what I mean. It is my feeling that we can do the same thing here with **HVR**.

I challenge every cannabis based brand out there to take the opportunity to sign up for a free account while they are still free and use this extraordinary new web platform to take your sales, branding and creativity to a higher lever.

Click here to check it out ->

**JOIN ME!**

Before I forget, I would like to wish you a very happy **Family Day** and **Valentine's Day**! In honor of **Valentine's Day** this year we check out some of our favorite Canadian cannabis couples and see how cannabis helps to keep the love they have as strong and flavourous as the day they said I do...

Take care and have a happy and high month of February!

**Cy Williams**

Publisher/Editor

**High! Canada Magazine**

editor@highcanada.net

Digital Downloads available

at **www.highcanada.net**

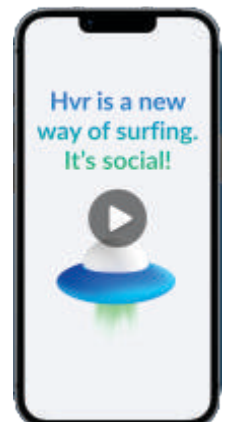



# HIGH! CANADA MAGAZINE



**HONOURING LOVE & CANNABIS  
WITH A LOOK AT OUR FAVORITE  
CANADIAN CANNABIS COUPLES**

In this special feature on love and cannabis, we look at six prominent couples within the Canadian cannabis space and ask them for their thoughts on cannabis and their own relationships. Remo and Sandra from **Remo Nutrients** and **Remo Farms** simply declared their love for each other and we snagged this amazing photo of them touring around Ontario promoting the new Supercharged joint from Remo Farms. Our other couples all submitted their thoughts and it only re-enforces my feeling that love and cannabis go together extremely well. I would however, like to look at this from all angles.

I began to suspect that cannabis and love were deeply connected a few years ago when researchers at the University of California discovered the link between the “love” or “hug” hormone (oxytocin) and the effect of marijuana on human behaviour that improves interpersonal bonding. Oxytocin triggers the release of a chemical called the “bliss molecule” (or anandamide), which helps to activate brain receptors and increase happiness and motivation. Testing this with animals showed that mice which were given the marijuana, which stops anandamide deterioration, reacted as they enjoyed spending time with their mice mates much more, than mice that were served with a placebo drug.

This is the first study of its kind to look at weed and oxytocin, and on a serious note, looking into this further could help scientists know more about oxytocin and social impairments, like autism, and potentially develop new methods to tackle symptoms of autism.

More recently, a Rutgers study indicates that cannabis users appear to be less aware of unhealthy relationship strategies they may use with their partners when discussing a conflict.

The study states that cannabis users

may think their approaches to managing conflict in romantic relationships are better than they are and don't recognize potentially problematic dynamics that might exist, according to a collaborative study conducted by Rutgers and Mount Holyoke College.

The study, published in the journal *Drug and Alcohol Dependence*, is one of a few to examine how cannabis use is associated with how couples relate. Researchers say the findings can assist couples in which at least one of the partners uses cannabis better navigate conflict discussion and resolution.

“We looked at different indicators of relationship functioning: how satisfied and committed people felt about their relationship, their behavior and physiology during a laboratory-based conflict interaction and their perceptions about their conflict discussion and relationship afterward,” said author Jessica Salvatore, an associate professor in the department of psychiatry at Rutgers Robert Wood Johnson Medical School.

In the study, 145 couples in which at least one partner used cannabis were asked to report how often they used the substance and how satisfied they were in their relationship. The couples were videotaped engaging in a 10-minute discussion on a topic that they identified as a major source of conflict, during which researchers measured their physiological stress response through their heart rate and respiration.

The couples then had a five-minute discussion on an area where they were in agreement. After, researchers asked how they thought the conversations went and how satisfied they were with conflict resolution.

The videos were observed by two sets of trained raters who assessed each partner's conflict behavior, including



avoidance (deflecting, skirting or ignoring areas of disagreement) and negative engagement (making demands for change, criticizing or blaming) on separate five-point scales.

A separate set of raters assessed the extent to which partners were able to transition out of conflict, regardless of resolution, toward a discussion of agreements and positive aspects of their relationship. They assigned low scores when participants made no substantive contributions to the discussion of positive aspects of the relationship and high scores when they nominated areas of agreement or positive aspects of the relationship or when they elaborated upon their partner's suggestions.

The researchers found participants who used cannabis more frequently showed less parasympathetic withdrawal during their interaction with their partner – indicating reduced capacity to flexibly respond to stress. They also issued more criticism and demands, avoided conflict during the discussion and were less able to reorient themselves to a discussion about the positive aspects of their relationship. Yet, paradoxically, when asked how they thought the conflict conversation went, cannabis users reported greater satisfaction with how the conflict was resolved and did not perceive themselves as having used demand or avoidance strategies.

“The assessments by the cannabis users were almost the exact opposite of what independent raters found,” said Salvatore. “However, it is important to note that this study's findings do not mean that cannabis use is wholesale good or bad for relationships. Rather, it gives insight into how couples can better navigate conflict and come to a resolution. When you don't see problems, you can't solve them.”

The study was conducted in collaboration with Katherine C. Haydon,

an associate professor in the psychology and education department at Mount Holyoke College.

Smoking cannabis with a partner can be the best shared ritual. Lighting up and staying in to watch movies in bed is always a cozy and nice option for a Friday night; laughing about dumb stuff for far too long is a bonding exercise that's probably scientifically on par with sex. Not to mention that actual sex while stoned is never disappointing.

But for couples who are mismatched in their habits, weed is a lot less chill—and a lot more complicated to navigate. Sober lovers tend to feel like their partner cares for their bong more than them. People who smoke, on the other hand, end up feeling judged by a partner who abstains. And giving up weed for a partner is never, ever an easy decision.

***Additional research reveals that cannabis use between couples increases might benefit their relationship, in the bedroom and beyond.***

“We found robust support for these positive effects within two hours of when couples use marijuana together or in the presence of their partner,” says Maria Testa, a social psychologist at the University at Buffalo and the study's lead author. “The findings were the same for both the male and female partners.” What they call “intimacy events” include demonstrations of love, caring and support.

For the study, Testa and her colleagues found 183 married or cohabitating heterosexual couples that had been living together more than six months, with at least one partner who uses cannabis a minimum of twice a week.

We only speak to five but what an amazing five to speak to...

# *Remo & Sandra*





## **FROM SANDRA:**

This year we celebrate 30 years of being together and our 25th wedding anniversary. Let me tell you about my very first date with Remo. We had previously met in a bank line up and decided after chitchatting back-and-forth. We would go on a date. It was Mother's Day, 1993 he took me out on a quad that he had just recently purchased and target shooting as he was known to do that time of his life. I have never been on a quad, and I certainly had never been target shooting. Both things that were very much out of my comfort zone. Best first date of my life!

We've been on a wild adventure together for 30 years. We've raised three children together and now we have four grandchildren. I married my best friend and I know that no matter what happens I'll always be able to say that I have had the best life.

We've been through the good and the bad, but all in all, we care about each other and respect each other's feelings, but always allow each other to be our true selves.

## **FROM REMO:**

"I love Sandra, she is my rock and I can't even begin to imagine life without her"





*Willy & Holly-Dale*





**THAT'S THEIR SONG... AT LAST, BY ETTA JAMES!**

**WILLY & HOLLY-DALE:**

He's a resourceful Canadian from frigid Sudbury, Ontario.

She's a vivacious American from steamy Cape Canaveral, Florida.

He wished every birthday for a sweet bubbly firecracker of a gal to understand his wacky ways.

She dreamed of a peaceful unconventional guy with good vibrations to skyrocket her heart, by helping others.

He's a humble guy with a heart of gold, passionate about solving problems.

She's an authentic, personable, partnership builder and connector of like-minded souls.

He's the legendary wacky mastermind innovator, diving deep into solutions impacting Craft Cannabis extractors.

She's the trusted advisor, educating, training and promoting his trail blazing solventless equipment solutions.







Together, they love and play hard, and empower each other to be their best. This Power Couple have had a bright influence on the Craft Cannabis Industry with Willy's trailblazing Solventless Extraction equipment innovations.

Making hash commercially feasible and profitable directly enables smaller producers the confidence to bring quality organic solventless products safely to market.

Their powerful award-winning partnership was celebrated with GrowUp's 2022 Best Equipment award for Willy's legendary all-mesh WackyBags and his newest innovations, the Arctic Boomer - Iceless Bubble Hash Washing System, the vibrated air agitated RocketSpa and his latest Arctic Plunge pressure agitator are all breaking ground in

solventless extraction. These never-before-seen methods gently wash and agitate to organically remove the trichome rich glands without plant shredding degradation .

Wacky Willy and his effervescent wife Holly-Dale say they are turning their Wacky dreams into reality by making hash production easier and profitable - so everyone can have some!

What's next for Willy and his blond bombshell muse?

Well...let's just say they have a secret recipe on the innovation table, coming soon!



FINALS

Amy & John



SMOKE ICONIC  
**PINNRRZ**™/MC



## FROM JOHN PRENTICE:

It's been an incredible eight years working alongside my wife, Amy, in the cannabis industry. Her vast communications experience and skills as a publicist and promoter make her an asset, and she has a keen intuition for developing brands.

Beyond her professional accomplishments, Amy is an incredible mother of our two children, and she works tirelessly at work and at home to support our family.

I couldn't do this without her by my side.

We are similarly full of ideas and her unwavering support and belief in our vision has been a driving force in our success. She handles challenges that come our way with grace and determination, and we face our past and present failures together in stride.

Amy's passion for the industry and drive to constantly improve herself and those around her is truly inspiring.

I am constantly in awe of her dedication to our family and her commitment to being hands-on with our children while balancing our demanding careers.

It's an honour to work alongside someone I think is such a remarkable person who is willing to go on this rollercoaster with me. I feel incredibly grateful to have her as my partner in life and in business.

## FROM AMY PRENTICE:

For the last 8 years, I have been lucky enough to pursue projects I'm passionate about and build companies side-by-side with my partner and best friend. John is a big thinker who inspires me every day to believe that anything can be possible.

John is admirably unafraid of risk and rallies with the best kind of energy to put ideas into motion. His optimism can be contagious and his willingness to take big leaps often pushes me to live outside of my comfort zones. I'm always learning when I'm around John.

At the height of the legalization of Cannabis, while our first start-up was quickly growing, our family grew too. Not only is John a bright founder and business leader, but he's also an amazing father and the brightest light in our two children's lives. He balances business and family, navigating how to nurture and be present for both, often willingly sacrificing time for himself.

John's ambition, commitment, and courage to lead makes him one of the bravest people I've ever met. Building start-ups is simultaneously the most challenging and exciting thing we've ever done. We don't live 9 to 5 lives and often brainstorm long into overtime hours, but together we invest in our ideas and each other and we have a lot of fun. John brings laughter and light into our home, and he always keeps me on my toes in business and in life.

The logo for PINNRZ features the brand name in a bold, stylized font. Each letter is composed of multiple parallel lines in shades of blue and purple, creating a 3D, metallic effect. A small 'TM' trademark symbol is positioned to the upper right of the 'Z'.

### About PINNRZ™:

John and Amy Prentice are part of the founding team at PINNRZ™, the iconic, slim joints that are designed to provide a new experience, nostalgic and familiar, to Canadian consumers in a classic form. PINNRZ™ was founded in 2021 and operates under license by Final Bell in Bowmanville, Ontario. Join us on the journey and learn more about our products at [pinnrz.com](https://pinnrz.com). Follow us on Instagram and on Twitter @Pinnrz



*Sheri & Jeff*



**SMOKER**  
FARMS

*Small Batch Craft Cannabis*

## FROM JEFF AUBIN:

Coming from the black/grey market, there have been many challenges. We had previously referred to it as the “roller coaster”. You just never quite knew what was coming! Now with legalization, it is still a “roller coaster”...just a different one and we have been there to support each other through it all!

During the building of the facility, I had moments of uncertainty where I was second-guessing our decision to take this on. I was worried that it was taking us somewhere we wouldn't be able to get out of. Sheri talked me down telling me she believed in me and that she was my biggest cheerleader. At every step of the journey Sheri calmed me down.

In my 25-year career I was used to doing things and making big decisions by myself but for this project I had the support of my wife to achieve my dream for both of us. In all stages through the planning and building of the facility, Sheri was involved. Even though my wife had a full-time job she devoted countless hours to paperwork, talking to our consultant and working into the wee hours of the night while still having to go to work the next day. Sheri told me we would do anything necessary to support this dream.

If you don't have a serious bond with your partner, this journey will crush you. It is not for faint of heart! The challenges come hard and fast and need solving quickly. It takes a strong team to overcome these challenges. One of our ways of overcoming these challenges is having a daily celebration where we reflect on our day and recognize the small victories and what we are grateful for. Sometimes it is just for making it through the day!

I wouldn't be where I am without my wife, nor would Smoker Farms be a dream I could realize.

## FROM SHERI AUBIN:

Through our 28 years together our support for each other has grown. We have always been a great team with me having the secure career and Jeff exploring his passion for cannabis.

I had no idea his endeavors would lead us to a successful legal cannabis business that we could work at together. It is a dream come true for both of us!

I have always admired Jeff's passion and skill for cannabis and was more than supportive when the opportunity to legalize presented itself.

I had the utmost of confidence in Jeff. I used to have to withhold my pride for Jeff and what he did, but I can now shout it from the roof tops, and I do! I am his biggest cheerleader and fan!

It has not been an easy journey, but we have supported each other through the ups and downs, tears and laughter. When one goes down, the other is there to pick him/her up. It's a good balance! Laughter and fun are key to our relationship.

As business owners, our communication has improved...it had to! There is no time for arguments.

We are getting very good at discussing, apologizing, hugging it out and moving on. I have also improved my skills on admitting when I am wrong!

We are grateful for this opportunity to share our story and reflect on how we support each other.

It is just another way for us to appreciate each other and what we have built together.

I wouldn't choose anyone else but Jeff for this journey!



## Bio – Jeff Aubin

I have had over 25 years of experience in the cannabis industry in the black, grey and now legal market, all contributing to making me the grower I have become. There have been many challenges to overcome through the years, but I do believe I can now be my authentic self in the legal market. The illegal market has made me who I am, and I believe it is something that people are interested in seeing and hearing about, for which I am flattered. My big career accomplishments have been acquiring my legal license and tackling social media. It was a bit rough at the beginning but now I can share my candid moments in the industry with my followers. I am very excited about the skills this journey has opened up to me and look forward to what the new and “budding” market has in store for me.

## Bio – Sheri Aubin:

I have an administrative background. I was with BC Cancer for 25 years as an administrative assistant and later Clerical Supervisor. Due to the workload associated with the business I transitioned to a part time role with the local School Board office in Claims Management. I have recently been able to “retire” from the public sector to dedicate myself fully to Smoker Farms and the cannabis industry. Navigating the industry and reporting systems have been challenging but I have improved and expanded my skillset and I now am looking forward to fully embracing all that Smoker Farms has to offer and seeing where this journey is going to take us. I can't wait!



**SMOKER**  
FARMS

*Small Batch Craft Cannabis*







*Randy & Charlie*

## **RANDY & CHARLIE ROWE:**

Randy and Charlie are the dynamic duo behind Grow Up, a premier Canadian cannabis industry conference, expo and awards show, operating since 2017.

What defines this couple is their ability to seamlessly run a successful business together while balancing the demands of a marriage.

*One of the secrets is their deep love and appreciation for each other. They understand that a strong relationship is key to working together effectively.*

They regularly schedule date nights and take breaks from work to maintain a healthy balance in their relationship.

Another key ingredient is their ability to support each other during the ups and downs.

They understand that it takes a team effort to succeed and are always there for each other, no matter what.

*This unbreakable bond has allowed them to weather any storm and come out even stronger on the other side.*

Their shared passion for the cannabis community and the goal to create a platform for industry professionals to connect and learn from one another has been the driving force behind the success of Grow Up.

“Working together has only strengthened our relationship.” says Randy. “We understand the importance of shared goals and the benefits of working as a team towards a common purpose.”

This power couple is a true inspiration for what can be accomplished when two people work together with a shared passion.



*Natasha & Matt*





## FROM NATASHA SMITH:

I've known Matt Durrant for 12 years and feel very lucky to have him in my life.

His energetic and charismatic attitude inspires me everyday to do what I love, and his sense of humour is super infectious.

Matt has taught me to take risks in life, supported me along the way and is always my biggest fan.

He encouraged me to grow cannabis professionally and I look at him as a mentor and my best friend.

Matt and I have grown cannabis together for a long time, 10 years now.

Initially, we grew for medical purposes at our own ACPMR and more recently for the legal recreational market.

We have hunted genetics together and brought them to market, including our Collector's Cup winning phenotype of the strain, Cookies N Cream X Purple Punch 2.0, that was featured by HighTimes.

***We enjoy working together everyday and get asked all the time "How do you do it?" We make an awesome team, have an undeniable respect for one another, and are both passionate about this plant.***

## FROM MATT DURRANT:

Natasha Smith is a passionate cannabis grower. She really does love this plant and it shows in her art. There are a lot of people in this world but only one Natasha! She is not only an amazing human but an amazing grower as well. She approaches cannabis cultivation like an artist in that she looks at every room as a canvas and the strain as the paint. She has this amazing ability to mix science with intuitiveness that yields a one-of-a-kind result.

Natasha grinds in the garden day after day and maintains a positive attitude that both plants and people just want to be around.

Her crops are always beautiful end to end and her buds stand out with a vibrant uniqueness.

She truly is a master of the game! I might be biased, but I think Natasha grows the best weed north of the boarder. I'm just the lucky guy that gets to smoke it everyday!

Currently, we are both working with a micro cultivation facility in Alberta called Alberta Keef.

We are dedicated to becoming the most respected craft cannabis wholesale supplier in Alberta by providing a premium quality and consistent flower, supported by an environment of passion and trust.

Alberta Keef is a place where there is meaning in our work and every job is valued.

7TH ANNUAL

# PREMIER GROWER'S CONFERENCE & EXPO

INTERNATIONAL GROWERS • SUPPLIERS • EXTRACTORS • MANUFACTURERS • DISTRIBUTORS



## BRAND & BUYERS ZONE

CALLING ALL CRAFT, MICRO AND STANDARD LPs



**PRIME TRADESHOW  
BOOTHs STILL AVAILABLE**  
visit [growupconference.com](http://growupconference.com)  
for more information



Flower Submissions are Open until February 10th, 2023.  
Concentrates submissions open until April 1, 2023. Open to  
Health Canada Licensed Producers Only  
(Standard/Micro).  
[canadiancannabischampionship.com](http://canadiancannabischampionship.com)

**GROW YOUR BRAND**  
Get direct access to Canada's largest retail  
buyers. Secure your brand's tradeshow booth  
and be a part of this must-attend event.  
**Reserve Your Brand Space Now**  
[growupconference.com](http://growupconference.com)

**GROWUP** CONFERENCE & EXPO  
EDMONTON, ALBERTA • VICTORIA, BC  
MAY 28-30, 2023 • EDMONTON CONVENTION CENTRE

3,500 ATTENDEES • 120+ SPEAKERS • 120+ EXHIBITORS • NEW BRANDS & BUYERS ZONE  
1-866-GROW-UP-1 • EDMONTON, AB • VICTORIA, BC • [WWW.GROWUPCONFERENCE.COM](http://WWW.GROWUPCONFERENCE.COM)





## HIGH! CANADA MAGAZINE

# WHY JEWS LOVE WEED

**BY LISSA SKITOLSKY, PH.D.**

As a recent immigrant from the U.S., I am currently living my best life as a student in a program on Cannabis Cultivation with Dr. Av Singh at Nova Scotia Community College. However, in our post-Kanye era, and as a Jew in Kentville, NS (are there others?), I tend to get a bit jumpy every time we discuss Israeli methods of cultivation or learn about a Jewish educator, such as Dr. Raphael Mechoulam or Dr. Lester Grinspoon who played a pivotal role in cannabis research, or talk about a Jewish activist, such as Ed Rosenthal, Jack Herer, Allen Ginsberg, or Dr. Ethan Nadelmann who played an important role in the cannabis legalization movement (not to mention Bob Dylan: “Everybody must get stoned”).

On one such occasion I blurted out: “Hey I just gotta say that there are a lot of Jews who love weed but it’s not because we own the industry.” I didn’t elaborate on why we love cannabis, as it’s always awkward acting as the Jewish representative, and I didn’t want to inadvertently reinforce the Neo-Nazi view that cannabis legalization is a Jewish conspiracy meant to keep everyone stoned (or, for that matter, Nixon’s view that the reason “every one of the bastards that are out for legalizing marijuana is Jewish,” is because “most of them are psychiatrists”).

So I was thrilled when I learned that Jews like me are now called “Cannabis Jews,” to signify that our cannabis use is connected to our

spiritual practice, Jewish ancestry and culture. And we are now holding conferences and writing about why we love weed so much (Baruch Hashem!). In her articles on Jews and drugs for cannabis magazines and the Jewish press, Madison Margolin writes about the use of cannabis in different Jewish communities and emphasizes its ancient role in Jewish religious practice (Cannabis Jews love to mention that the Bible and Talmud include directions for its proper use and preparation, where the Hebrew term—*kaneh bosem*—is most likely the origin of the word “cannabis”).

As a Cannabis Jew who has spent a lot of time getting



high with very chill Canadians, I think it's easier to understand why Jews love weed by recalling what we don't believe rather than what we do, as it helps to explain why we've never had an issue with a plant that helps us heal. In particular, if we keep in mind that Jews don't believe in original sin, we can start to understand why we have a very different sensibility of nature and a different approach to pleasure than the Christian

tradition, that places us in a position to love and honor the cannabis plant as a sacred gift from God. For Jews, it doesn't make sense to view any natural desire or bodily appetite as inherently bad, when we are born with the freedom to choose how we satisfy our desires, in a manner that can help to repair the world or tear it apart.

Further, we don't believe that God holds a grudge or

consigns people to eternal suffering for their sins. It's not that we don't have a notion of the afterlife—"Olam ha-Ba," the "world to come"—but it's pretty vague and not something that's emphasized in our ethics. In other words, we don't aim to be good people in order to avoid divine punishment, but rather because it's our responsibility to help repair the world through good actions that respect the sanctity of all living things (in my view, we can grasp the basis of Jewish ethics in our toast, "l'chaim"—"to life"). From this perspective, it's easier to understand why so many Jews love weed, or regard cannabis as a sacred herb provided by God to help us cope with pain so that we can better attend to the needs of others and recover from history.

We also observe Shabbat, the Jewish sabbath, for the same reason, and believe that we need to take some time at the end of the week to rest from our daily grind in order to feel some awe, and resist the cynicism that can undermine the desire to be ethical and repair the world. As reported by Margolin, many religious Jews view the consumption of cannabis as helpful in this effort to chill out, observe Shabbat and connect with God—no matter what else is going on in the world.

Finally, if you've seen an episode of *Curb Your Enthusiasm* or have been to New York City, then you know that many Jews can be



# HIGH! CANADA MAGAZINE



kinda cranky, in part due to historical and generational traumas. In this regard, it helps to remember that most of our holidays commemorate occasions when we were persecuted and nearly eradicated because we're a group that seems to annoy everyone. This can affect our general worldview. For example, when Freud discovered the pathology of trauma and the psychic compulsion to repeat suffering, he concluded that his prior emphasis on our predisposition toward pleasure had been all wrong. We are not driven by the desire for happiness or pleasure, for trauma indicates the presence of “masochistic trends” and a “daemonic force” at the core of our psyche. In my experience, this is how many of us feel when we attempt to reconcile the arc of Jewish history with our status as the “chosen

people,” and it's hard to feel optimistic or a sense of pride when we are so often described in negative terms such as neurotic, anxious, and pushy (to name a few).

So, it's not so surprising that Jews love weed and have played a prominent role in the movement to legalize cannabis, since we have always consumed it as medicine, both to cope with the past and to feel a bit more positive about the future. And for sure, I think Larry David could benefit from a daily dose of CBD (full spectrum extraction, of course). For now, I'm proud to represent as a Cannabis Jew and say l'chaim when I light up in Nova Scotia.

**BY LISSA SKITOLSKY, PHD.**

**Nobody accommodates cannabis enthusiasts better than we do.**

**Where do you find  
the best 420-friendly vacations  
this fall and winter?**

**[www.hibnb.ca](http://www.hibnb.ca)**





# WOMEN IN WEED

## LAINIE RUTH

**H**igh Canada Magazine was thrilled to speak with Lainie Ruth, aka @thesoberstoner420 on Instagram.

Lainie has an amazingly inspirational story and we are super happy that we can share it with you here today.

High Lainie! Can you tell us

a little about who you are and what you are currently involved in?

*My name is Lainie Ruth aka "The Sober Stoner 420". I am the Founder of Recovery with The Exit Drug (est. 2013) — the first non-profit support community for people using cannabis as an*

*exitdrug to replace or reduce their use of dangerous and addictive substances.*

*My alias The Sober Stoner 420 acts as a public advocate and activist for cannabis, harm-reduction, & substance use disorder/addiction recovery.*

# WOMEN IN WEED LITTLE ROCK



How did you get involved with cannabis?

*I got involved with cannabis after an accidental cocaine overdose.*

*This overdose happened after many years of using alcohol and deadly drugs excessively as a teenager. After several inpatient rehabs, outpatient programs, support meetings, counselors and*

*medications, nothing could stop my substance use disorder aka addiction.*

*Fortunately, a dear friend recommended I try to use only cannabis as a replacement for the drugs and alcohol that were literally killing me. And to my surprise, it worked!*

*Ever since then, I have been sober 13+ years with*

*the help of cannabis medicine.*

How does cannabis factor into your everyday life?

*Besides cannabis acting as a life-saving medicine for myself everyday, I decided to dedicate my time to help others learn about cannabis as an alternative option for finding recovery from addiction.*





*In 2013, I created the first available online support community for folks interested in using cannabis as an exit drug from substance dependence. I volunteer my time for this mission and mentor individuals that are struggling daily. I also work with amazing cannabis brands to promote quality products that are safe and effective.*

Have you encountered any challenges or adversity as a cannabis user?

*Unfortunately, I have encountered many challenges as a cannabis user. Jail, rehab, job interference — all which transpired unjustly.*

*Jail happened due to an unlawful search and seizure, rehab was forced upon me for my cannabis*

*use due to a psychiatrist who is publicly renowned for endorsing old cannabis propaganda and myths, and the job interference happened due to me being a public figure for cannabis, therefore leading some angry online stalkers to call my place of work.*

*The important point is that none of these adversities changed my*



# WOMEN IN WEED LAINE RUTH



*mind about the healing powers of this plant.*

*These situations only act as proof that cannabis is still heavily stigmatized to this day. I choose to fight the stigma by being honest about the wrongdoings I have endured as an advocate and patient, and by continuing to bring awareness to the truths of cannabis.*

Advice for other women entering the cannabis space or thinking about trying cannabis for the first time?

*Any women entering the cannabis world should know that it is a warm welcoming community, but that it can be very competitive because of the unavoidable rat race there is to create the foundation of legal and medical cannabis. Come*

*in confident, educated and passionate and you will find your way.*

Last question - What are three things that you think everyone needs?

*3 things I think everyone needs?*

*Love, laughter and health, cannabis can help one find all three.*



# The Only Vegan Organic, USDA Certified Fertilizer On the Market.

Grow Cleaner. Grow Better.



Our USDA certified Organic Fertilizer is patented and designed to promote the growth and harvest from your vegetation, along with protecting yourself from the harmful synthetic chemicals found in traditional fertilizers.

Our nutrients are optimized for use in fertigation lines, and cause no clogging issues.



[www.humblebeesbotanical.com](http://www.humblebeesbotanical.com)

*Humble Bees*  
BOTANICAL SUPPLIES INC.

[www.highcanada.net](http://www.highcanada.net)

# HIGH! CANADA MAGAZINE

## HOW A.I. & CANNABIS INTERSECT...

By Cy Williams



**A**s of late, A.I. has been at the forefront of many of our discussions around the watercooler, around the boardroom and across our many forms of social media and messaging. , there have been many exciting developments in the world of A.I, including many new automation solutions for crop cultivation processes worldwide. It is easy to see that A.I. has many applications for the cannabis industry and can help creatives, retailers, big and small growers and many others within the cannabis industry. Artificial Intelligence (A.I.) has rapidly become one of the most transformative technologies of the 21st century. It has quickly changed the way we live, work, and interact. A.I. has already been integrated into many industries including healthcare, finance, retail, and entertainment, and its impact on society and business has been substantial.

Artificial intelligence is a powerful tool that is also being applied in all aspects of the cannabis industry. New technology is helping growers produce better crops and identify the right



times to scale their growing operations. For suppliers and sellers, A.I. driven technology can also create more accurate demand predictions, so they can avoid being out of stock on the wrong products.

As we move into the future of A.I. and the cannabis inventory, we can expect software to support more aspects of cannabis operations, from content marketing to sales.

In this article, we'll look at recent applications of A.I. technology within the cannabis industry and with optimism, we will look to the future for other upcoming developments and how they will potentially change the nature of how we currently work within the Canadian and International cannabis space.

The increasing implementation of A.I. for sales and marketing isn't exclusive to the cannabis industry but can help boost your bottom line.

With more predictive analytics and more accurate customer data, you can generate campaigns that are more likely to work and develop sales pitches that are better tailored to your specific audience members.

In the world of sales, A.I. can help you identify the best sales opportunities — leads who are likely to convert with a nudge, churned subscribers who could reactivate with a follow-up, and more. In the marketing realm, A.I. technology is already helping many business leaders (including cannabis business leaders) instantly generate compelling content and save time.

A.I. isn't just helpful for creating general content. It can be programmed to help create content that complies with the laws that cannabis companies have to follow — for example, by helping you avoid restricted mediums or animations that could be attractive to minors.



With many cannabis companies facing social media suspensions and ad deletions, new A.I. software is helping companies flag potential issues in their content, including hashtags, captions, and visuals that could initiate bans or shadow-bans on key marketing channels.

While the future of the cannabis industry could introduce more relaxed rules surrounding content marketing, age restrictions will continue to make A.I. driven compliance essential.

As you may have heard, growing cannabis can come with many challenges that are very unique to the plant. For example, creating the right level of humidity and sunlight is key to maximizing production. A.I. technology is changing and adapting to help farmers monitor the conditions



of their growing environment. With the addition of A.I. and robotics to the list of tools available - cannabis growers are able to use this technology to implement essential and often time sensitive changes as soon as they are needed. Growers can use this technology to reduce the likelihood of unhealthy crops. A.I. operated sensors and cameras that can be used to detect plant growth rates and other indicators of plant health can help cannabis growers detect sick cannabis plants and can also help identify the proper treatment that is needed for each plant. This can lead to a massive reduction in overall loss and an increased yield.

A.I. can also improve cannabis crops by using incredibly accurate insights into production and the conditions that yield the best results and cultivators can utilize A.I. to assist in creating strains with higher THC, CBD, CBG and CBN percentages, greater pest resistance and greater bio-availability.

A.I. can be incredibly helpful to cultivators and sellers, when it comes to meeting the changing needs of consumers. A.I.



can help professionals track more information about product preferences, consumption habits, and even more.

A.I. can also be used to help companies predict inventory levels based on current sales and supply. Instead of manually tracking inventory, sellers can use modern software to get instant notifications about low inventory and, if desired, automate supplier orders. This technology can also help sellers identify products that aren't moving quickly enough to be cost-efficient, so they can remove those items from their inventory or raise their prices.

For cultivators, AI-enhanced inventory management tools can also help identify expansion opportunities. When sales start

moving quickly enough, cultivators can use AI to weigh the potential profits and risks associated with scaling their growing operations.

In the modern age of this current cannabis industry, A.I. can play a major role in improving customer support by making it increasingly more efficient and less dependent on the human factor. Growers and sellers can use A.I. driven product-matching tools that can help medical patients and recreational consumers identify the best products and dosages for their needs. Instead of requiring a consultation, even beginner cannabis users can quickly determine what kind of cannabis they will need for the best experience.

We have all seen the rise of quality A.I. driven chatbots on websites and now customers can get answers to common questions without ever speaking to a human being, which reduces wait times while helping these clients get answers faster. In theory, this frees the human agents' time to handle more complicated support needs. We imagine that will soon change as A.I. driven technology continues to expand and improve.



A.I. technology can also help companies mine data from social media mentions, website traffic, and more to generate insights about the right products to both produce and sell.

### **Recent Developments in A.I. that may forever change the space:**

**The increased popularity of AI art generators.** This is a general term referring to software that uses artificial intelligence to automatically create images. These tools often come in two forms: text to image or image to image. Text-to-image generators are able to create unique images based on a user's text input, which is also commonly referred to as a prompt. This is changing the game for illustrators, artists,



writers, photographers and publishers and repercussions are being felt all across the art, marketing and communications world. I know that amazingly creative individuals are creating some amazing work. I see aesthetically stunning and beautiful art posted online by incredibly talented people within the Canadian cannabis space. People like Riel Roussopoulos and Owen Smith and Shawn Smith (no relation) and I am staggered by the sheer possibility of what can be accomplished. This is a medium like no other - literally no limits but that of an all too human imagination.

Our cover art was provided by Trim Queen in her own quest to understand what A.I. can do for her and the accompanying graphics that are featured in this article are all A.I. generated thanks to Shawn and we were blown away by what Shawn submitted.

Next up is **ChatGPT**. The GPT stands for “Generative Pre-trained Transformer”.

**Translation:** this is a next level, nearly omnipotent chatbot that’s incredibly articulate and conversant.

While the core function of a chatbot is to mimic a human conversationalist, ChatGPT is versatile, including the ability to write and debug computer programs; to compose music, teleplays, fairy tales, and student essays; to answer test questions (sometimes, depending on the test, at a level above the average human test-taker); to write poetry and song lyrics; to emulate a Linux system; to simulate an entire chat room; to play games like tic-tac-toe; and to simulate an ATM.

**This has some professionals wondering if ChatGPT will somehow replace essential human services in the legal, medical or cannabis industries.**



The 3rd development of note occurred in November of 2022, when automation leader Eteros acquired Bloom in order to make good on their promise to deliver groundbreaking computer-vision and superior Artificial Intelligence to the cannabis industry.

As the parent company of the Trinator and Mobius brands, Eteros seeks to provide post-harvest processing solutions for all levels of cannabis production. The acquisition of Bloom strengthens Eteros' ability to deliver on that goal by bringing computer vision and artificial intelligence (AI) to cannabis producers.

Although Ag-tech has been one of the fastest-growing sectors in conventional farming and is expected to top 15.3 billion in 2025, Ag-tech in cannabis is still in



its infancy. Eteros hopes to change this with the acquisition of Bloom.

As competitive as the cannabis market is today, this is only expected to increase as the market unfolds. In cannabis, there are so many areas where producers use manual labor because they need humans. We, do however, see the tremendous opportunity that implementing Bloom AI into harvest automation would gain in terms of competitive advantages.

*“By combining Bloom's technology with Mobius, we can equip operators with a powerful new data set to help them make better decisions and enhance their level of*

*automation,”* said Aaron McKellar, CEO of Eteros.

This Ag-tech integration comes at a critical time for cannabis cultivators facing price reductions across the board. These price reductions are forcing cultivators nationwide to evaluate their harvesting methods. Although many of the processes have been mechanized previously,

Eteros believes that integrating Bloom technology, which uses a sensor array and AI-driven algorithms to collect data, will improve the precision, accuracy, and efficiency of existing automation. In addition, the technology will enable an entirely new wave of

processing capabilities, including defoliation, harvest weight predictions, pathogen identification, and foliage density assessment, which was one of the main drivers for the acquisition. *“Our mission has always been to bring AI and robotics to all areas of the cannabis industry. By joining Eteros, we can seamlessly create intelligent automation across a broad ecosystem of new and existing products,”* said Jon Gowa, the CEO of Bloom.

What are your thoughts on A.I. and how it intersects with cannabis?

**Blown your mind yet?**

~ **Cy Williams** ~



Even though cannabis has become an uproar in most countries cities and towns throughout the world, it is not quite as widely accepted as one would think.

Let's look at Thailand. Cannabis was introduced to Thailand as ganja from the Indian culture. The Indian culture cannabis was seen and has been seen throughout history being utilized more as a medicine than as a alleviation or a recreational drug. This aided in the transition from having cannabis available to those who only held a viable prescription relating to ailment in which a physician had found it appropriate to prescribe - to something else entirely.

With Thailand being the first south Asian country to eliminate cannabis from their narcotics list as a category 5 narcotic in June 2022, the decision had surprised and is surprising not only their neighbours but throughout the world. Thailand has been recognized to have in place some of the strictest rules and regulations when it comes to any type of mind-altering drug/narcotic. From fines to incarceration, the penalties that followed if one were to be caught by enforcement would be facing a hefty find and or jail time. In November 2023 Thailand officially decriminalized certain properties of the plant i.e. The buds and leaves for recreational use. Along side the specific part of the plant in which is legal Thailand has also cannabis plant for legal use for all Thais. extracted cannabis content must have less than 0.2%. The prohibiting of individuals who are under the age of twenty, pregnant and or added women who may be breastfeeding are

# HIGH! CANADA MAGAZINE CANNABIS AROUND THE WORLD

By Debi Facey

also restricted from having and using cannabis recreationally. One of their laws that they have created and have to the current restrictions surrounding cannabis is that any Buddhist monks and novices from smoking or growing cannabis.

Unfortunately, Thailand has seen a rise in shops, creation of products exceeding the government's THC limit and the rise of the bold using in public spaces which has and still sticky frown upon and falls under their any "act of public disturbance" set in 1992 which inhibits one from smoking and/or carrying the scent. Violators of this law can face a 25,000 baht (around \$690) fine and three months of imprisonment.

Below is description of the repercussions following any kind of dismay when it comes to their laws:

## What is the legal basis for drug-related offences in Thailand?

The Narcotics Act 2522 (1979) and the Psychotropic Substances Act 2518 (1975) have provisions for drug-related offences.

## How do the two acts define various substances?

**The Psychotropic Substances Act defines psychotropic substances as being natural or derived from nature, or synthetic as the Minister notifies.**

Schedule 1: not used for medical purposes and have a high tendency to improper used or abused.

Schedule 2: used for medical purposes and have a high tendency to improper used or abused.

Schedule 3: used for medical purposes and have a moderate tendency to be improperly used or abused

Schedule 5: used for medical purposes and have less tendency to improper use or abused.

## Example of the repercussions For Category 1 Substances:

Up to life imprisonment and a fine of 1,000,000-5,000,000 Baht, or the death penalty, is levied for production, importation or exportation of controlled substances, and up to 10 years imprisonment or a fine of 20,000 - 200,000 Baht for possession.



# HIGH! CANADA MAGAZINE CANNABIS AROUND THE WORLD

By Debi Facey

Example of the repercussions a schedule Under Category 5:

The penalty for producing, importing or exporting cannabis is 2 years in prison and a fine of 200,000 Baht. The penalty for possession is 1 year in prison and a fine of 20,000 Baht.

Thailand's Narcotics Act defines narcotics as substances that cause physiological or mental effect in a significant manner and are classified into five categories.

Category 1: heroin and amphetamine

Category 2: cocaine and morphine

Category 3: ingredients subjecting to the regulations stipulated by the authority in charge.

Category 5: narcotics that contain chemicals used to produce.

Example of the repercussions For Category 1 Substances:

Up to life imprisonment and a fine of 1,000,000-5,000,000 Baht, or the death penalty, is levied for production, importation, or exportation of controlled substances, and up to 10 years imprisonment or a fine of 20,000 - 200,000 Baht for possession.

Example of the repercussions a schedule Under Category 5:

The penalty for producing, importing or exporting cannabis is 2 years in prison and a fine of 200,000 Baht. The penalty for possession is 1 year in prison and a fine of 20,000 Baht.

What powers do drug enforcement officials have?

To search any place or dwelling place for illegal drugs, or if the officials have reasonable grounds to suspect that a delay would result in the escape of any suspects or the drugs being hidden, destroyed or transformed. To enter and search premises without a warrant, to order a person to undergo "on the spot" drug tests, to arrest anyone involved in the commission of any offence related to illegal drugs, to seize any illegal drugs, and to make inquiries.

**By Debi Facey**

Owner of @EverytingcannaPublishings and @The Collective Highs

Ontario Contributor @  
www.highcanada.net

Canada's Cannabis Correspondant @  
www.procannabismedia.com

Budtender @ www.tokecannabis.com



www.highcanada.net

# HIGH! CANADA MAGAZINE

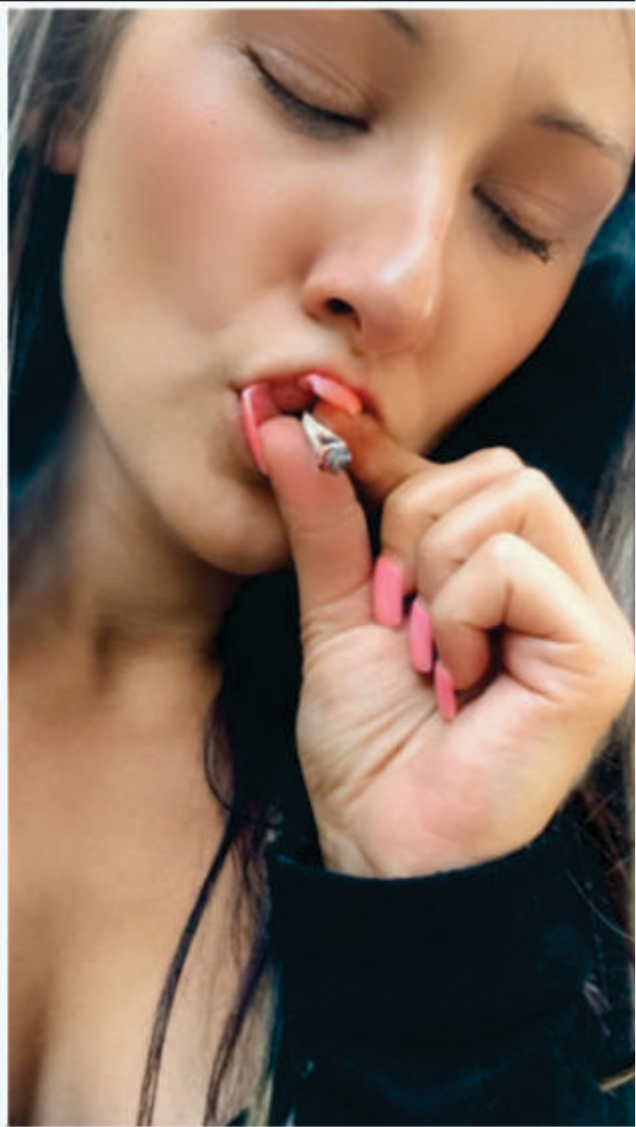

## CONFESSIONS OF A CANADIAN STONER

Curated by Sara Jane Wilson

# HIGH! CANADA MAGAZINE

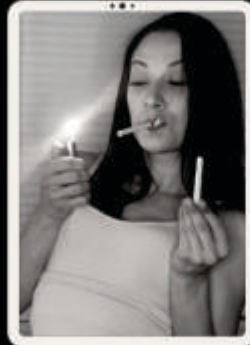
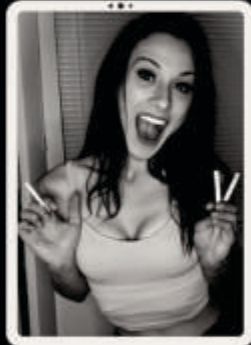
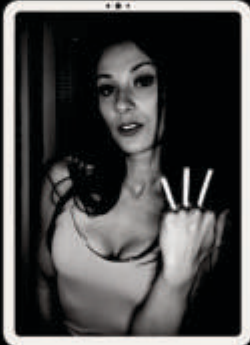

I'm always down for trying new foods when I'm baked and one night I ended up ordering every single item on the menu at a Chinese restaurant.

I couldn't stop laughing at the names of the dishes and convinced my friends to try them with me. We ended up trying out everything from chicken feet to thousand-year-old eggs and it was the most interesting and funniest night ever. I don't remember what the food tasted like but I do remember it was the best night out I've ever had.

**- Braden**

I got really high on edible gummies and decided to make s'mores in the middle of the night. I couldn't find any graham crackers or chocolate. I proceeded to roast up marshmallows on a camping stove and eating them straight off the stick. I ate the entire bag of marshmallows and went to bed with sticky fingers and a sugar high...

**- Arthur**

I smoked a joint before picking up my kids from school and I was convinced that I was hiding it well, but as soon as I saw

them, they both said "Mom, you smell like weed." I was mortified and didn't know what to say. I had to come up with a quick excuse and said that I was experimenting with new candles. I felt bad but also couldn't stop laughing.

**- Anon**

So there we were, a group of college girls in Toronto, sitting in our dorm room and trying to come up with something fun to do. We decided to order in some pizza and watch a movie, but as soon as the delivery guy left, someone suggested we all get





stoned first. Fast forward an hour, and we were all sitting on the floor, trying to figure out what kinds of pizzas we'd even ordered. We ate them straight out of the box, even though we had plates on the coffee table next to us. And the majority of us fell asleep half way during the movie. We weren't

the biggest of stoners and we couldn't handle our weed, to say the least."

**- Tanya**

**T**wo years ago I found myself in a crisis. I was put off work after a violent incident in the emergency

department where I worked and was struggling with burnout and coping mechanisms that only exacerbated the poor state of my mental and physical health. The night of the incident was a binge, but the day after, I knew everything had to change. I knew my life would slip away from

me if I didn't start treating my self and my life with more respect and gratitude.

How did I (immediately) start making radical changes in my life? With weed. I smoked weed everyday.

It helped by dissolving the anxiety of a profound moral crisis while alleviating the cravings and urges I had for alcohol. It helped make my world feel like a softer and gentler place to be. The greatest change I was able to make was beginning a commitment to consistent and progressive improvements to my physical health through exercise. I started very simply with walking. Just walking (outside).

Prior to the incident, I felt incapable of overcoming the shame of my bad habits. This kept me in my house and in a dark place that perpetuated a cycle of negative thoughts and behaviours. Weed walks helped

evaporate that cycle and I am finally able to live in a world I want to be in.

I have changed a lot in the last 2.5 years and I hope to change a lot in the next 25. I feel optimistic and confident about my presence and my future. Thank god for those weed walks.

### **-Katherine**

I have a confession to make. I made some pot brownies a few weeks ago and I left them out on the counter when my friend came over. Her mother was also there and she ended up eating some of the brownies without knowing they were infused with cannabis. I was so scared and guilty, I didn't know what to do.

In the end, THANKFULLY, her mother was a stoner and knew what had happened. I can't even imagine what would have happened had it gone differently.

### **-Hattie**

To make a long story short, I was in a car accident over 20 years ago. I hurt my C5 and C6 vertebrae. Right off the bat the doctor at the hospital put me on Oxycodone.

Years went by and I developed chronic pain, insomnia, panic attacks, and I became agoraphobic.

Not only did my neck get hurt but my right shoulder dislocates every now and then. Doctors put up my oxycodone, put me on pills for sleeping (did not work), put me on pills for my panic attacks and so on. Before I got hurt I would smoke weed to get high, have fun.

After years of being a pill guinea pig for the Dr's. I tried weed. All those pills were making me, not me.

So I quit all the pills, I detoxed and started smoking weed. I found out it helps with the pain, my attacks, my fears and also my depression.

I fought my family





doctor for medical marijuana for 2 years till he gave in. I got my card. I only smoke weed for all my symptoms. I could have lost my family or my life on those pills. Now I live.”

**-Albert**

**A**t a recent family reunion, my cousins and I snuck away from the crowd when no one was looking. We found a secluded spot, lit up some joints and got super high. We couldn't stop laughing and couldn't stop thinking about the delicious BBQ food that was being served. We ended up sneaking back into the reunion and pigging out on all the food while trying to play it cool and act like nothing had happened. It was definitely one of the more memorable reunions I've been to.“

**-Whitney**

TO BE FEATURED, PLEASE SEND  
YOUR CANNABIS CONFESSIONS TO  
[INQUIREWITHSARAJANE@GMAIL.COM](mailto:INQUIREWITHSARAJANE@GMAIL.COM)  
PLEASE INCLUDE IF YOU WOULD LIKE TO  
REMAIN ANONYMOUS, AND/OR  
THE NAME YOU'D LIKE TO USE.  
PLEASE WAIT FOR 1-2 MONTHS  
FOR PUBLISHING.



[www.highcanada.net](http://www.highcanada.net)

**HIGH!**  
**CANADA**  
**MAGAZINE**

**REVIEWS**



**MANTRA**  
CANNABIS

**W**e were so excited to receive our box in the mail containing the Mantra Cannabis Dawn and Dusk Oil-based Tincture Drops so that we could complete a proper Product Review.

After a week of using both the Dawn 50 CBD Extract in the morning for seven days and using the Dusk THC Extract every evening before bed for seven days - we were seriously impressed. From Dawn to Dusk, Mantra Cannabis has you more than covered with their line of Premium CBD and THC oils carefully

curated to enhance each and every magical moment of your day.

Mantra Cannabis's new Cannabis Extract Drops - Dawn and Dusk are sure to fly off the shelves as one of the best liquid cannabis extracts on the market. With the CBD infused product - Dawn and the THC infused product - Dusk, these cannabis extracts are truly a dream product or magic at the very least.

Using a combination of MCT coconut oil (which gets absorbed through the liver so the cannabinoids can be broken down and absorbed at a faster rate

than normal tincture) and Sea Buckthorn oil (which is rich in various vitamins and minerals, as well as antioxidants).

Sea Buckthorn oil can aid your heart by reducing blood pressure, as well as improving cholesterol levels, and protecting against blood clots.

That said, its effects may be strongest in people with poor heart health, and with its distinctive orange colour and unique taste - it certainly gives Mantra's product a distinctive look that sets it apart from other similar types of product.





Mantra's THC Infusion Dusk is great for relaxing after a hard day's work as well as helping you doze into a long and restful sleep.

As for Dawn, the CBD infusion is a great addition to anyone's morning vitamin regiment as it is great for beating away that morning brain fog and can help you face the day with vigour and clarity of both mind and body.

These Products really showcase the best of the cannabis industry - blending tradition with contemporary techniques. Mantra is certainly one of the better health-focused Canadian companies moving forward in this industry because they do it by honouring the past and that is refreshing to see and experience.

I for one look forward to seeing what magic Mantra Cannabis will come up with next.

**By**  
**Cy Williams**  
**with Xander Landry**

**HIGH!**  
**CANADA**  
**MAGAZINE**

**FIVE STAR**  
**PRODUCT**



for all your accessories



[trimqueen.co](https://trimqueen.co)



# HIGH! CANADA MAGAZINE

A woman with her hair in a bun, wearing a black life vest and a black mesh top, is smiling and looking to her right while sitting in a raft on a river. The water is white with rapids. The background shows a lush green forest with trees and a small waterfall in the distance.

## TRIP QUEEN ADVENTURES IN JAMAICA

In June 2022 I had the pleasure of going on an epic 15-day road trip around Jamaica and loved it! Going on a journey, moving with the land and learning and experiencing new things as you go along is priceless!

Tip #1 learn the laws of any country you decide on travelling to.

### **JAMAICA LAW FOR POSSESSION OF CANNABIS:**

Despite its decriminalization for possession, the sale and supply of cannabis (widely known across the country and world as Ganja) for recreational purposes remains prohibited in Jamaica. Since 2015, possession of up to two ounces of cannabis is no longer a

criminal offence. However, it must be medicinal and you must have your medicinal card or get fined J\$500 (USD 3.50) but no criminal record will result. Possession is also legal for sacramental purposes for followers of Rastafari.

Visitors may have possession of up to two ounces of cannabis however it must be for medicinal. However, as laws toward ganja for recreational has loosened up it is not as strict as you may





Westmoreland to be exact. This is not your typical resort-style tourist outing. When I arrived at Benta Park and it was on a hidden path and the roads here are poorly maintained so if you're not used to driving in Jamaica I recommend using a taxi service. Benta Park is gated so you will need to pay a fee to get in. For Locals in the area, it's free.

The tour of the river is not your typical tour. You are assigned a tour guide and listen to your tour guide do

experience however keep in mind it's still illegal to consume in public spaces and purchasing from a legal dispensary is highly recommended.

Dispensaries in Jamaica have to abide by strict rules and regulations. Some have farms to sell options and tours. Again, no medicinal card no service. Some dispensaries have on-site doctors to issue medicinal cards but check with the

dispensary because on certain days the doctor is there. Let's say you don't have a medicinal card and don't want one there are other options you may explore, cannabis tours, small local vendors (which we are not supposed to recommend but use your judgment) you can find some decent buds.

I got invited to a typical Sunday Bbq by the river from local cannabis farmers. Benta Park in Savanna-La-Mar,

not trail off, play expert. If you can't swim I recommend a life jacket and water shoes are mandatory if you don't have either it is available to rent on-site.

This place surprised me beyond words.

From Rapids yes rapids and from the roar of the water you are yelling at one another, gliding thru small cascades of water getting a natural massage from the water beating your back. I





www.highcanada.net

# HIGH! CANADA MAGAZINE

didn't know a place like this existed. This is probably the most thrilling activity and underrated place I have ever visited in Jamaica.

The water is filled with minerals from the rich limestone and clay that sits on the river bed! At one point of the tour, you do get to stop and put the clay on your skin like a mask at no extra charge.

The clay kept my skin clear for the remainder of my trip.

Everything from the stairs leading to the river is used from the land this is an eco-paradise. You surely don't want to miss it.

Now let's get to the good part. After the water tour, the aromas start to hit you from the pimento

bark bbq pit -to the sweet smell of ganja which is freely used at this park.

As we sat down and enjoyed some cold drinks while listening to the music that filled the park it was surreal. Everyone was relaxed and I got the chance to sit down with the farmers and have a growing talk! It was interesting to hear





people genetically modified food where it grows faster and can reap faster where so many health concerns are rising ~it boils down to what will they touch next...” They want what they grow to remain organic and preserve the authenticity of the plant. Being an organic grower myself I can agree with this. It was an intriguing conversation that did leave me with some food for thought.

about different methods and how testing has been more commonly used among farmers. Organic farming has been key for these farmers some even have said, “Why alter something that’s not broken? Our grandfathers grow like this, our fathers grow like this, we will do the same and we can only hope our children grow like this!” However, a lot of worries have come down to the future of ganja in Jamaica from the farmers. Some of the farmers have been sought out by licenced producers worldwide including from Canada. Overseas producers have allegedly been giving cannabis seeds which have struck a chord with the farmers as

they believe it’s genetically modified seeds and have refused to use them the reasoning behind this is the “food foreigners eat” the farmers have discussed and said “...if they can grow and feed

Benta Park is indeed a hidden gem.

**One Love,  
Stay High, Stay Happy  
and Stay Safe!**

**TrimQueen®**





# Canada's Favourite

## Seaborn Organics Squid Based Plant Nutrient

Seaborn Organics Squid Based Plant Nutrient  
(Affectionately referred to as 'Squid Juice')

2-2-2 NPL Liquid Concentrate

Our products are available for sale exclusively through [www.GreenFlowCanna.com](http://www.GreenFlowCanna.com)  
and are available in 1Litre, 4Litres, 57 Litre Drums & 265 Gallon Tote



## Organically Increase your Crop yields.

From Sea to Soil Squid Juice is made from Squid by product fished for Calamari Consumption.

Creating a sustainable 100% organic plant nutrient.

Promotes crop and soil health, give your plants what they need to thrive.

Proven and Guaranteed Amazing Results!

**GreenFlow Canna Corp**  
195 King Street, Unit 106  
St. Catharines, ON. L2R 3J6

1-905-327-5929 1(888) 552-3651  
[info@greenflowcanna.com](mailto:info@greenflowcanna.com)



Larger and Commercial orders available upon request.

# HIGH! CANADA MAGAZINE

## ORGANIC vs SYNTHETIC WHAT'S THE REAL DEAL HERE?

By **Dave Mac Adam**

Organic plant care is growing a healthy plant without the use of synthetic fertilizers and pesticides. It's about taking care of the soil, which in turn provides the foundation for a healthy plant. It's also more than that.

Organic plant care is a philosophy that considers and cares for the entire ecosystem, including the water supply, people, animals, and insects, as well as the soil.

By using naturally derived products, you're working with nature, not against it. You're able to maintain the

natural cycle by regularly replacing nutrients plants have used.

Adopting an organic plant care strategy reduces pollution in the atmosphere, nutrient run-off into waterways, waste in landfills, and the inorganic products used that may disturb the natural order hidden in the soil. You're really not taking care of grass, you're nurturing the soil so your plants have the best opportunity for healthy growth.

Fertilizers come from many sources. Synthetically derived fertilizers are

manufactured from minerals, gasses from the air and inorganic waste materials. Fertilizers derived from organic sources obtain their nutrients from natural sources such as microbes, organic waste, and other similar materials.

### What are Organically Derived Fertilizers?

Fertilizers derived from organic sources provide benefits to both plants and soil and when used properly generally won't burn or damage plants. Organically derived fertilizers stimulate beneficial soil microorganisms and

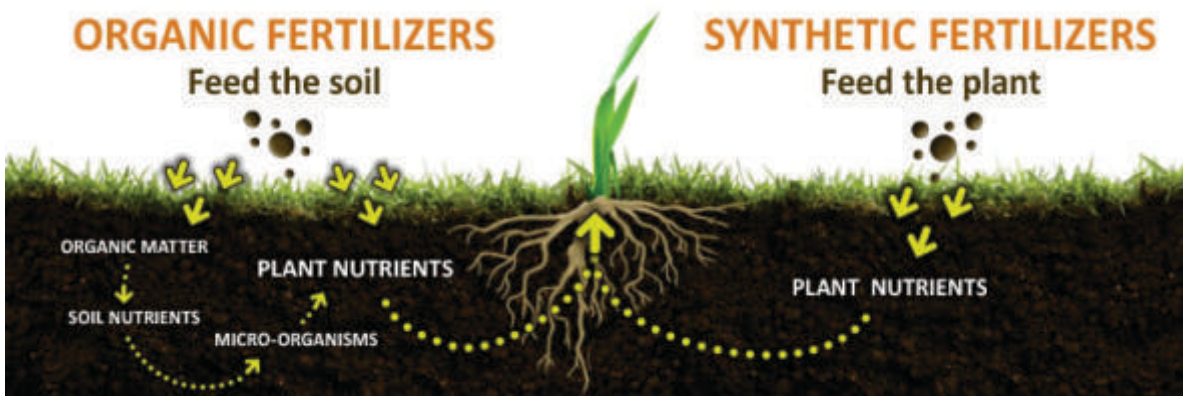





improve the structure of the soil. Soil microbes play a key role in converting organic fertilizers into soluble nutrients that can be absorbed by plants at a rate they can use.

Organically derived fertilizers often provide the secondary and micronutrients plants need, usually absent in synthetic fertilizers.

Organically derived fertilizers typically have a lower NPK analysis (nitrogen, phosphorus, potassium) than synthetic fertilizers, but they feed plants for a much longer period of time. As a result, the impact of organic fertilizers on plants is usually more subtle. It may take a little longer to see results, but the reward is a plant that sees its true potential.

If you are going to go with soil the important thing to remember is that the key to a

healthy garden is healthy soil—a living, breathing ecosystem.

The primary components of soil are minerals (inorganic materials), organic materials, water, and air. The organic matter improves the soil's capacity to hold water and nutrients, releasing them as needed by plants. It feeds the microorganisms, which in turn makes nutrients available to plants, as well as improves the soil structure.

Water makes it possible for the plants to absorb those nutrients, but that's only the start.

A healthy soil ecosystem is teeming with beneficial bacteria, fungi, and countless microorganisms, as well as the critters we can see, like earthworms and insects.

Fertilizers derived from organic sources feeds the soil, which allows the nutrients to be released

slowly, at a rate consistent with what plants need, when they need it.

Plants receive a well-balanced diet, including a broad range of vital, naturally occurring trace minerals and micronutrients. Nutrients released slowly stimulate consistent growth and root development and don't need to be applied as often. Synthetic fertilizers release nutrients quickly, promoting rapid growth that is often excessive. You need to understand how to properly flush your cannabis if you are using a synthetic nutrient. Flushing cannabis removes leftover nutrient buildup from the roots and soil of your plants giving them a fresh start. Flushing effectively allows your plants to absorb any nutrients that are still in the soil. By flushing your cannabis plants before harvest you can avoid a harsh and extremely unsatisfying end-product.

**By Dave Mac Adam**

# HIGH! CANADA MAGAZINE

Interviews, Insight, Experience and Education

## HCM Interviews

**You**Tube



HCM Interviews - Michaela Freedman...  
High Canada

**You**Tube



HCM Interviews - Jim Belushi  
High Canada

**You**Tube



HCM Interview with Steve DeAngelo  
High Canada

**You**Tube



HCM Interview with Josh Creighton  
High Canada

SUBSCRIBE OR WE WILL COME OVER TO YOUR HOUSE AND SMOKE ALL YOUR WEED!

[www.youtube.com/highcanadamagazine](http://www.youtube.com/highcanadamagazine)



# LEARN HOW TO GROW CANNABIS FROM ED!

Ed Rosenthal has been teaching people how to grow marijuana for decades. Let him help you cultivate bountiful buds, and lots of them.

**Ed Rosenthal's Cannabis Grower's Handbook** is the definitive guide for all cultivators—from first-time home growers to experienced large-scale commercial cannabis operators. The Grower's Handbook breaks down the fundamentals of marijuana cultivation and demonstrates their practical applications in gardens of any size. Learn new techniques to maximize yield and efficiency and to grow bigger, more potent resinous buds!

**Cannabis Grower's Handbook** covers the newest lighting technologies such as LED and adjustable spectrum bulbs; permaculture and regenerative farming techniques; advanced drying and curing methods and strategies; comprehensive integrated pest management; and over a dozen specialized garden

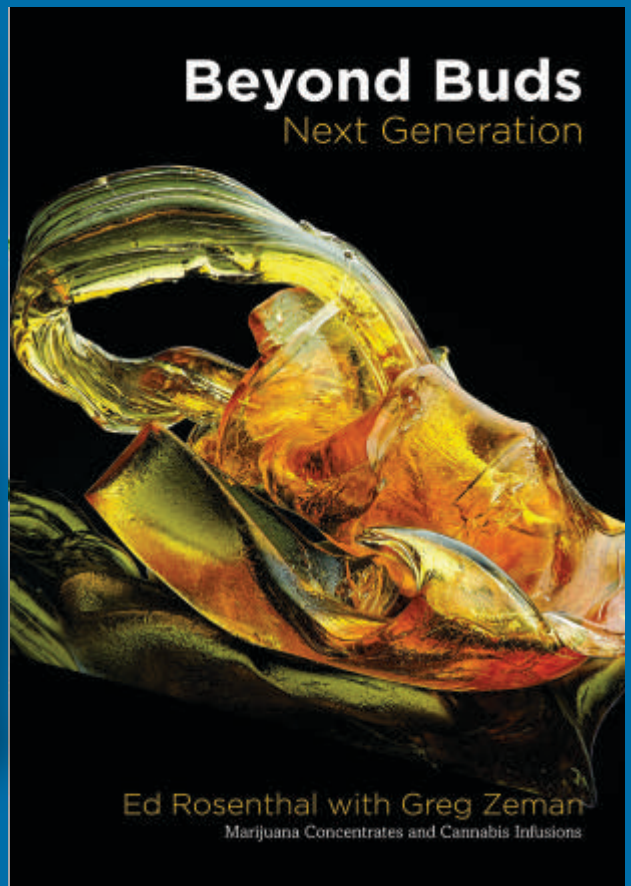

setups. Still deciding what to grow? This guide will help you choose among the many options from innovative breeders, which now include autoflowering plants and CBD and CBG varieties of hemp. With over 600 pages of full-color photos, this grower's guide presents the latest science, tools, and methods to enable you to grow a cannabis garden of any size, anywhere—indoors or out.

Ed Rosenthal's books are known for their easy-to-understand and trend-setting content and have educated millions of growers—hobbyists and professional cultivators alike consider Ed's books their go-to guides. This fully updated edition of Ed's groundbreaking **Marijuana Grower's Handbook** comes at a time when more people than ever before can legally grow cannabis and want to know how to maximize their yields. Once again, Ed shows you how, this time drawing on

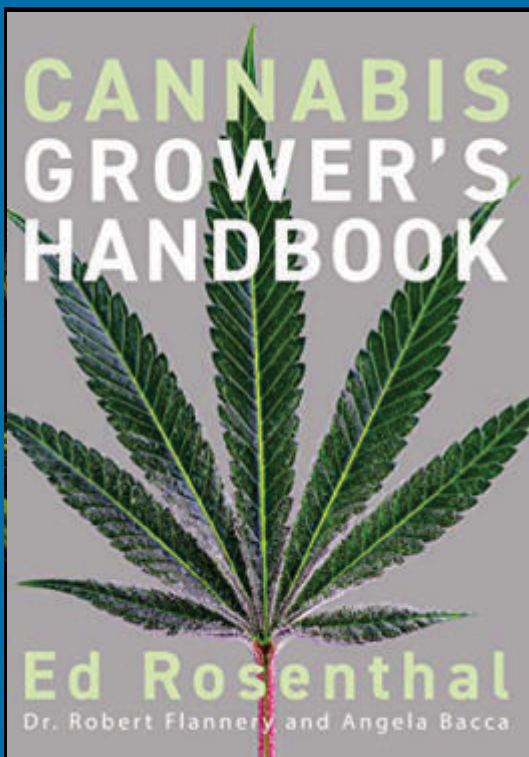

the contributions and research of the pioneers and leaders in the legal cannabis industry, as well as from professors at leading horticultural schools at the University of California at Davis, Cornell University, the University of Connecticut, and Oaksterdam University.

Two new co-authors have contributed their expertise to **Cannabis Grower's Handbook** - Dr. Robert Flannery holds a Ph.D. in plant biology and is the founder of Dr. Robb Farms, a licensed cannabis producer in California. Angela Bacca is an editor and journalist who has specialized in cannabis content for over ten years and edited the 2010 edition of the **Marijuana Grower's Handbook**. Dr. Robb and Angela Bacca join Ed Rosenthal to bring the must-have Cannabis Grower's Handbook to a rapidly "growing" audience.

Ed has a number of great books out there. **Another is Beyond Buds -Next Generation: Marijuana Extracts and**

## **Cannabis Infusions is here!**

Are you interested in exploring the world of marijuana beyond the bud? In **Beyond Buds, Next Generation**, 'Guru of Ganja' Ed Rosenthal, author of the much-loved Marijuana Grower's Handbook & Greg Zeman, Assistant Editor at Cannabis Now will walk you step-by-step through the most cutting-edge methods of cannabis consumption.

If you want to stay up to date with the latest innovation and developments in the cannabis industry, this book is for you. **Beyond Buds, Next Generation** is designed to help you:

- Discover the benefits of CBD and other healing cannabinoids.
- Understand what Co2 extracts are and how to make them.
- Learn the inside scoop on rosin and resin.
- Stay up to date on the latest developments in dabbing gear and culture.
- Decide which vape is right for you.
- Reveal the latest trends in spa products and cannabis services.
- Teach you the cutting-edge techniques being used in CO2 and BHO concentrates.
- Use simple tools and techniques to easily turn your extra trim into hash, salves and lubes.

The burgeoning concentrate industry is evolving with unprecedented speed and relentless innovation.

**Beyond Buds, Next Generation** is your authoritative guide to the latest developments.

**Get these books on Amazon!**



# HIGH! CANADA MAGAZINE

## H O M E G R O W N A N O U T P O S T O F C O M M O N S E N S E

BY @TFPRUDENTHEWRITER

**H**ello neighbor,  
and welcome.

Somehow, I'm looking at February on the calendar tacked to the kitchen wall here at Pajama Flats.

*The days are longer, with light enough to see until late afternoon, now. But once again, I search for words by which to entertain us.*

That, after all, is what I'm about here.

As usual, however, this gig, like most others I've

enjoyed, finds me a fish out of water. Or so I've been told. By now, too many times to count.

I will also admit, it seems I may have, again, chosen to ignore the obvious.

Maybe it's because my hearing, like everyone else's, is highly selective.

And I'm not talking about an indica or sativa high, either.

I mean, if I thought it could be pulled off, I'm sure I'd have tried denying it by now. But for me, it's tough denying the facts.

Mostly because one of the many blessings here

is a set of ears that hear well enough to make music.

*The producing and engineering credits only make it harder to deny.*

So, most times it's tough making a claim of 'I didn't hear you' stick.

Not only that, but when it seems otherwise, it's often an act.

*Thus, and many times, I've damned these elephant's ears.*

Then, there's the issue of my always protected

eyes. Once the tools of a hunter, after hurting them in a workplace incident years ago, I've lavished care upon them.

And though I wear glasses to read, neither age nor UV exposure has yet affected the former hunter's long-range sight.

*But they, too, are cursed by a need. Not to look away from what they see, but to record and keep the memory of it.*

Though often guarded by dark glasses to protect them from the sun's dangerous rays, a lifetime of writer's training means they, too, miss little.

I'm nothing, if not a product of training, work, and discipline.

Anyway, the latest word is that what I'm trying to pass off as a sense of humor is far too dark for the mass market.

Or anyone without either a thesaurus or a calculator handy.

Did I mention how this would be old news?

Well, if not, there you go. It sure is to me, anyway, if not you, too.

My reply has always come in the same form. You're reading it right now. But you ask, do I not care that those who make such claims might be correct? And yes, I believe myself able to hear you wonder.

*Though we're separated by who knows what amount of either time or space.*

For you, dear reader, it's a most salient point, I know. Because much would seem to rest upon my answer to so ruthless a question. Though, and no matter my reply, neither rest nor ease be granted by it.

Anyway, my answer to such a query was, is, and will ever be the same, a resounding no.

I'm also pretty sure, though, that means I'm a little crazy, but not enough to need help. At least, according to the sawbones. And that, if

nothing else, makes me laugh.

I hope it works well enough to keep you coming back here, every month, for more of the same. Because if a writer doesn't work, he not only can't eat, but will soon lose the tenuous grip he keeps on what we jointly accept as reality. And once again, I'm not talking about the fatties we love so well.

*See, nowadays, though legal weed is abundant, paying gigs for writers are on the endangered species list. And the money on offer, most times, amounts to theft of intellectual property.*

Still, to those lucky enough to have them, a death grip holds them in



place. And this old writer knows at least one thing too well.

*It's a fact the many thousands of cannabis industry workers now hitting the streets after layoffs across Canada will soon learn for themselves.*

There is no romance to being out of work.

*There isn't anything funny about it, either.*

Until next time, smoke 'em if you got 'em, and happy growing.

© **T.F. Pruden 2023**

for  
[@highcanadamagazine](https://www.instagram.com/highcanadamagazine)



# EXPLORE.

A close-up photograph of a woman's face, with her eyes looking directly at the camera. She is surrounded by and peering through a dense field of green cannabis leaves. The lighting is soft and natural, highlighting the texture of her skin and the serrated edges of the leaves.

hi

**CANADA**

LIST WITH US  
AND MAKE BANK.

BE PART OF THE NEW ECONOMY.

[HIBNB.CA](http://HIBNB.CA)

Photographer Instagram: @orangejk  
Models Instagram: @dreamyhalo.xmodelling





*Canna-  
Mamas  
are  
Dope!*

*By  
Zara  
Boorder*

*The  
Fit Canna  
Mama*

# HAPPY LOVE MONTH CANNNA FRIENDS!

Have you made plans to X & O with your favorite person this February 14th?

Tell me, what's it gonna be this year?

*A dozen or two (or even three) long stem roses is always traditionally favored along with hard to pronounce gourmet chocolates and customized sweets with lovey-dovey initials and hearts drawn in white, pink and red icing...*

Add to that an ultra romantic dinner out or a cozy stay-in home ambience, abundantly decorated with intricately laid rose petals and an intimate candlelit setting, worthy of filter-free photos to 'post & boast' about, the day after.

Yes my lovers and friends, it is the month of

Canna-Love-liness and there is no shortage in the variety of gift ideas out there to share with the one that makes your heart beat with purpose and admiration; the one that makes you catch your breath at the wonders of their beautiful aura, both inside and out; the one whose existence alone, makes you thank your lucky stars that you found your way into each other's heart space.

True, its overly commercialized and we all can show our loved ones just how much they mean to us any day of the year in our overall daily demeanor and our everyday acts of service but for those of us who DO enjoy the dramatic displays of affection and delights on the popular love day, no romantic gesture is too grand to share with the love of your life.

*Do you opt to give green flowers-the*



*dried green variety or bring over some new chewy edibles and a six pack of cbd kombucha - is that even a thing, yet?*

In any case, I hope your day of love is canna-fied to the max!

And with that, it is my pleasure to introduce our beautiful February Canna-Mama, Leigh Griffith, from the classically charming and steadfastly romantic, Province of Quebec...

*Ooh la la!*

by ZARA BOORDER  
@the.fit.canna.mama



# Meet Fellow Canna-Mama Leigh Griffith



## about me

Years Old	thirty-nine
Years Consuming	twenty one
Residence	Montreal, PQ
Occupation	Photographer <a href="http://www.leighgriffithphotography.com">www.leighgriffithphotography.com</a>
Children	16 & 11 years old

## favourites

Strain	gelatto 33
Food	poutine
Exercise	weights, pilates, biking and step aerobics 3x a week

### Time of day for a session

first thing in the  
morning ~ wake and  
bake!

wanna be our next  
featured  
Canna-Mama?

contact  
[@the.fit.canna.mama](mailto:@the.fit.canna.mama)

## re:consuming

"Before motherhood smoking helped a lot with my anxiety. After child birth, I feel like I smoke for the same reasons some moms drink wine. Parenting is a hard fulltime job and we deserve a reward."

"Would love to try cannabis wine, that's apoc; alcohol free. I heard it makes you feel social without alcohol (side effects)"

"In Quebec, we have to buy from one (government franchise SQDC) store

I'm just glad it's legal, and I'm not a criminal for a joint.

"7 days a week...\$250/month average consuming product."

# ILLUSTRATED GUIDE TO ROLLING BETTER JOINTS

BY KANDER LANDRY

## TRIPLE WIDE

(3-Paper) is a large joint made by combining 3 rolling papers to form one large rolling paper. Due to its large size this is a good joint to share with friends

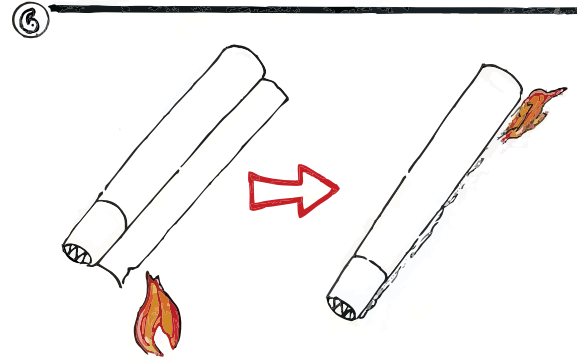
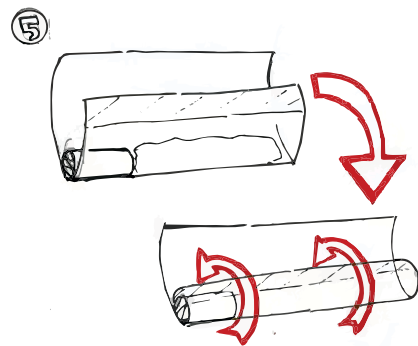
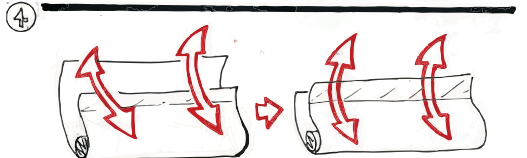
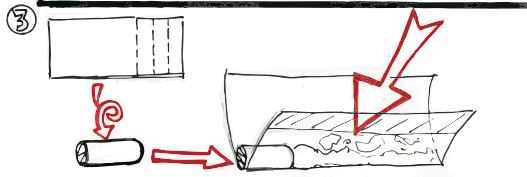
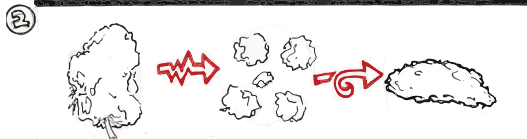
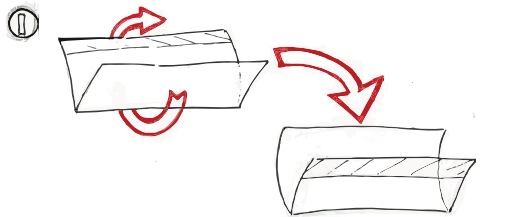
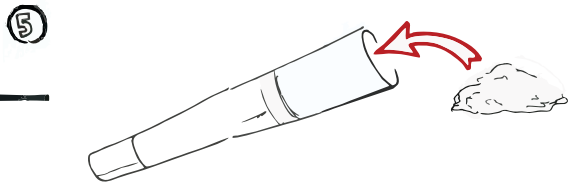
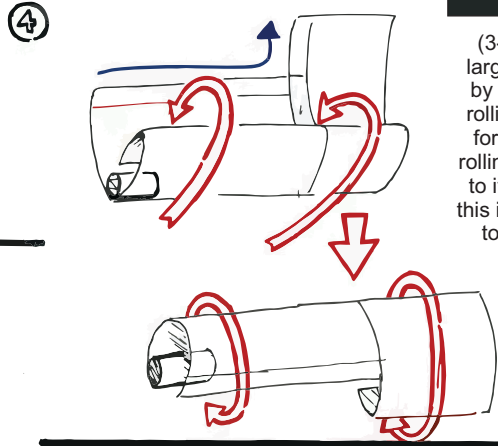
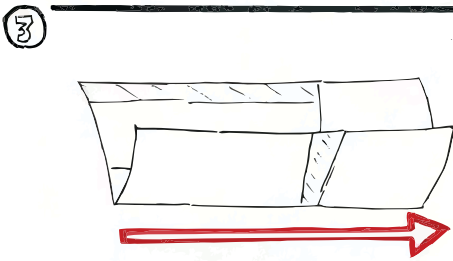
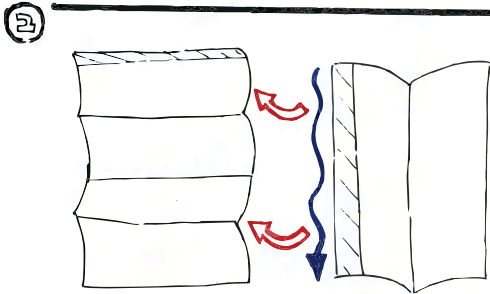
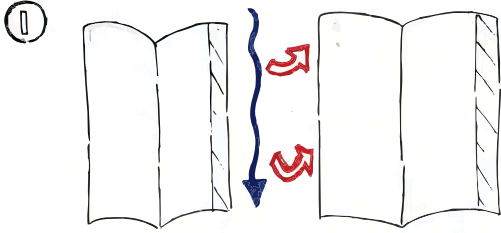

## INSIDE OUT

Also known as the Reverse Joint - this is a joint with the glue strip of the paper facing outwards instead of inwards and burning off the excess rolling paper,



# HIGH! CANADA MAGAZINE



## HARRY RESIN RETURNS!

**H**ow does one start an article when asked to re-introduce yourself to the world? Especially for a cannabis magazine.

How can I write this so that it does not come across as corny and arrogant? Well, for anyone who knows me, the latter is probably the most difficult, although I'd replace arrogant with confident.

That confidence was something that grew inside me over the years and I have one girl to thank for that: Miss Mary Jane. She has been an amazing teacher and companion all these years. I still find it remarkable how much a plant can teach you, even

one as special and unique as cannabis.

Cannabis for many people means many different things: for some it is a lifestyle, others a medicine and still others it is even a way to earn a living. As diverse as this plant is, so too is its relationship to all the people in the world it has touched. In some instances it can be both a blessing or a curse. Many have prospered as a result of coming into contact with it, but many have suffered as a result of being incarcerated for it.

Watching her grow and interacting with her was the start of a rebirth, a sort of red pill that freed me

from the box of the matrix. She opened my mind up to different avenues of perception and forever changed me. One of the most important traits cannabis has is the way in which it brings people together and creates community. By consuming it she can open your heart and connect you to all things.

Growing up in Amsterdam and spending a great amount of my time in the coffeeshops was really the first place I got to experience this connectivity. You'd have Arabs sitting with Jews, White people with Black people, and socialists sitting next to capitalists, but for that very moment



as they consumed this magical plant together, their differences melted away and they were united in the one love of this gracious lady: cannabis.

Had you asked this young kid from Montreal 30 years ago if he ever thought the right to consume this plant would be legal he'd have laughed at you. And yet here we are. I suppose in this lifetime stranger things have happened.

The process of legalization has been a long and arduous journey presenting many challenges and obstacles along the way. One of the most positive things to come of it is the

destigmatization of the plant. No one should go to jail for growing or possessing a plant Mother Nature intended for us to have and consume.

*We are, after all, built with an endocannabinoid system.*

Through my connection to the plant I have had the pleasure of traveling and living in many different places as well as meeting countless individuals who have also been greatly and positively affected by the plant.

I've watched the culture shift evolving from secret

smokey rooms to upscale consumption venues to cannabis being offered as a gift in the Oscar gift bags.

As the cannabis culture has evolved and gone mainstream many new advances in the cultivation, extraction and consumption of the plant have occurred. This has opened up the opportunity for more research into the medical benefits or the plant as well as how the plant's various compounds function in relation to each other and our own endocannabinoid systems. I really do feel like the best is yet to come.

Seeing how quickly things have evolved with the



# HIGH! CANADA MAGAZINE



industry in the last five years I believe we are in for some radical new developments. I'm looking forward to seeing more sustainable ways of farming and growing the plant.

Certainly on the genetic side we will see a rise in more stable cultivars and even improvement in the plant's yield as more stable seed stock becomes available. Science is also pushing forward with more clinical trials surrounding the active compounds found in the plant and the ways in which they affect us.

This will lead to greater understanding of things like flavonoids and other new cannabinoids we have yet to discover. This is an exciting time to be in the industry. Of course, as with all new things, we are

not without our own issues and problems that have risen as a result of overtaxation, packaging restrictions, and the influx of non-cannabis chads to the industry.

As cannabis moves more and more into the mainstream, and the barrier to entry no longer involves possible jail time, this becomes the trade off to seeing the plant evolve as well as the reduction of the stigma around it. I do believe it is up to us, the long time members of this community, to remain steadfast in our drive to protect this plant while at the same time educating new users to its benefits and helping shape what's to come.

As a long time breeder and cultivator I've always been attracted to the diversity the plant has.

Seeing how many different flavors, shapes and colors can occur within the plant's genetics has been a joy to see and experience.

The plant is one of the strongest most resilient plants I've ever seen. Seeing a plant go from almost dying because someone forgot to water it to popping back up and making happy leaves has helped inspire me to also be resilient. For me this plant is more than just something to grow and consume, she is an inspiration and a powerful companion that has been with me for the better part of the last thirty years, providing me with insights, clarity, and strength. For that I will always be grateful for having her in my life.

**By Harry Resin**



HORTICULTURE LIMITED

# ENHANCED PLANT GROWTH AND PRODUCT QUALITY

- INCREASED CANNABINOID LEVELS • INCREASED TRICHOME DEVELOPMENT & RESIN PRODUCTION
- ENHANCED TERPENE PROFILE • FASTER TRANSITION INTO FLOWERING • INCREASED FLOWERING AND BUD FORMATION • PROPRIETARY MANUFACTURING PROCESS OF OLIGOCHITOSAN • TRIGGERS TWO SEPARATE PLANT DEFENCE PATHWAYS • PROMOTES TOLERANCE TO SALT, HEAT, AND DROUGHT • CFIA REGISTERED

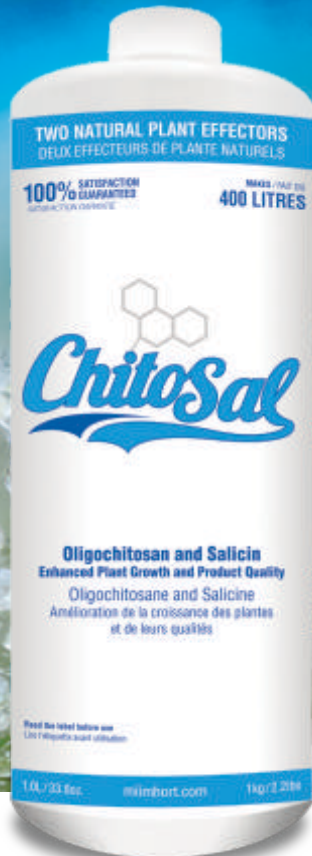

ChitoSal is an exciting scientific breakthrough in plant biology specially developed to improve plant immunity as well as vigour. It is composed of natural sources of oligochitosan and salicin. Both are powerful and proven plant effectors, which effect beneficial change at a cellular level within the plant.





HORTICULTURE LIMITED

# NEXT GENERATION BIOSTIMULANT

- SPECIFIC FOR CANNABIS AND HEMP PRODUCTION • FASTER ROOT DEVELOPMENT AND INCREASED ROOT BIOMASS
- FASTER VEGETATIVE GROWTH • INCREASED PLANT HEALTH AND VITALITY • THICKER STALKS AND STRONGER BRANCHES • INCREASED YIELD • HIGHLY EFFECTIVE WITH ALL NUTRIENT PROGRAMS AND GROWING MEDIA
- CERTIFIED ORGANIC & CFIA REGISTERED



MIIMCROBIAL MASS utilizes the latest scientific understanding in soil microbiology. We have created the perfect biostimulant which contains five targeted strains of beneficial bacteria that aid in the uptake of Phosphorus, Calcium and Iron like no other product on Earth.





BUYING QUALITY JOINTS FOR A LOVED ONE  
SHOULDN'T BE WHAT'S HARD THIS VALENTINES DAY.



SMOKE ICONIC  
**PINNRRZ**™/MC